

Załącznik nr 4 do zapytania

Znak sprawy: 37/BOCIAN2/2019

Schemat platform z mocowaniami

Rysunki poglądowe:

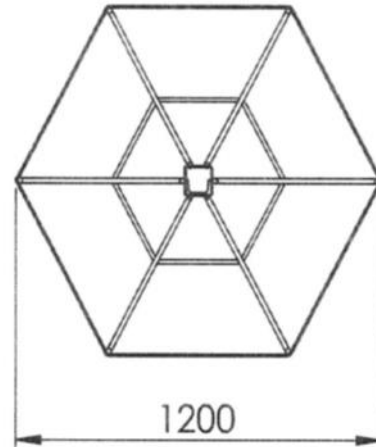
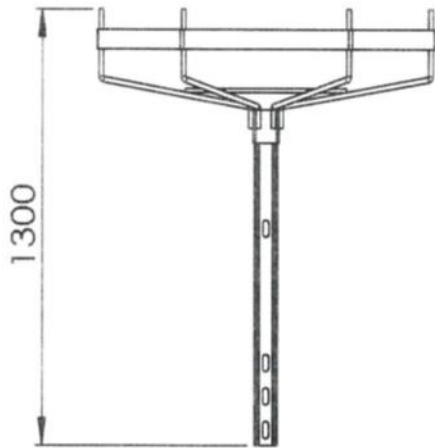



Z zestawem do montażu
na żerdzi E



Z zestawem do montażu
na żerdzi ŻN



Z zestawem do montażu
na żerdzi Aowej (klin KS-15)



Zakładane rodzaje montaży.

Montaż na żerdzi Aowej (klin KS-15)

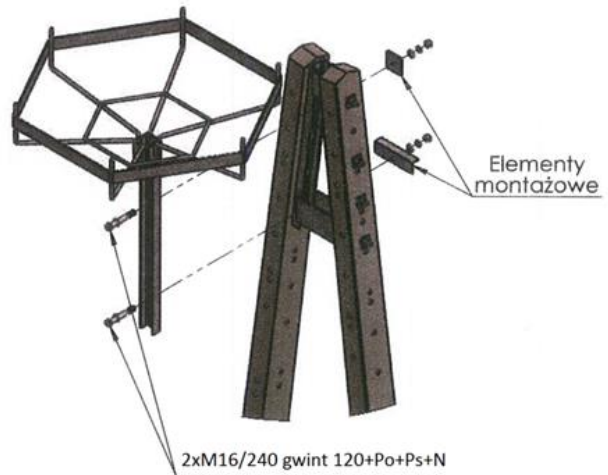

Montaż na żerdzi ŻN

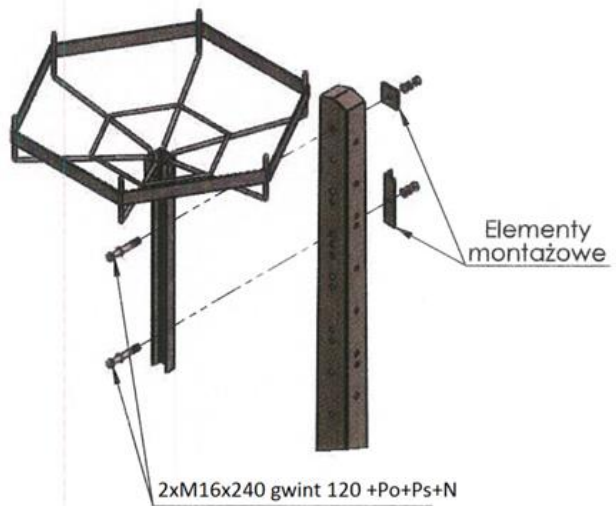

Montaż na żerdzi E

